

**FRONT VIEW
ON FITTING**

(SCALE 1:2 (A4))

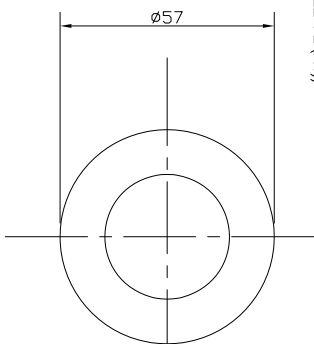

**ELEVATION ON
FITTING**

(SCALE 1:2 (A4))

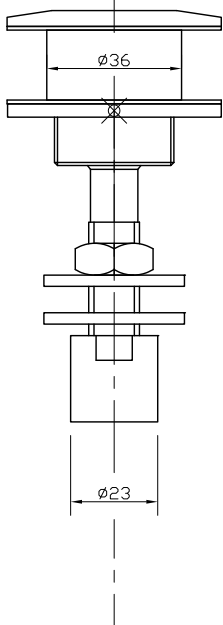

**DIMENSIONED
COMPONENTS**

(SCALE 1:2 (A4))

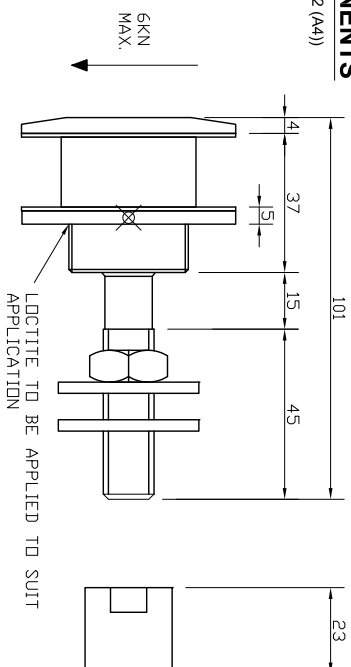

**REQUIRED
GLASS PREP**

(SCALE 1:2 (A4))

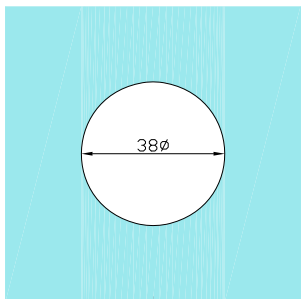

**ELEVATION OF
ARTICULATED
EXTENTS**

(SCALE 1:2 (A4))

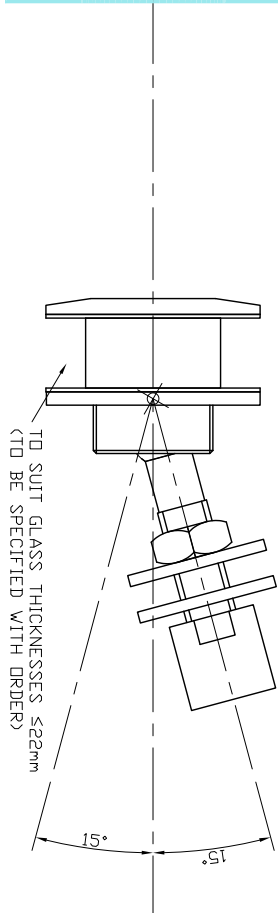

The Vision Group,
6 Barnes Close,
Brandon, Suffolk
IP27 0NY

TEL: +44 (0)1842 816086
FAX: +44 (0)1842 815515
WEB: www.spiralhardware.co.uk
E-MAIL: info@spiralhardware.co.uk

Copyright (c) - April 2008. All Rights Reserved

NOTES/SPECIFICATION:

ALL SPIDER GLASS FITTINGS ARE SUPPLIED IN GRADE 316 STAINLESS STEEL.

| | |
|---------------------|---|
| PRODUCT REF: | SH/ATS/A01 |
| DESCRIPTION: | DIMENSIONED ELEVATIONS AND REQUIRED GLASS PREP DETAIL |
| DRAWING REF: | SH/ATS/A01 - 001 |

ATLAS SPIDER FITTINGS APPLICATION EXAMPLES

**FACE FIXED
SPIDER FITTINGS**

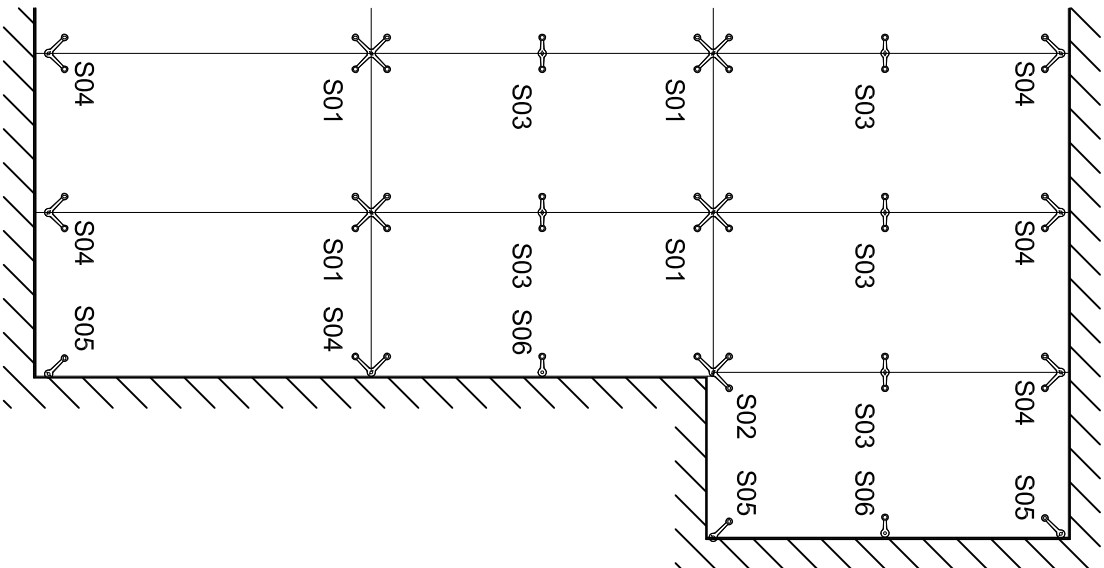

**APERTURE MOUNTED
SPIDER FITTINGS**

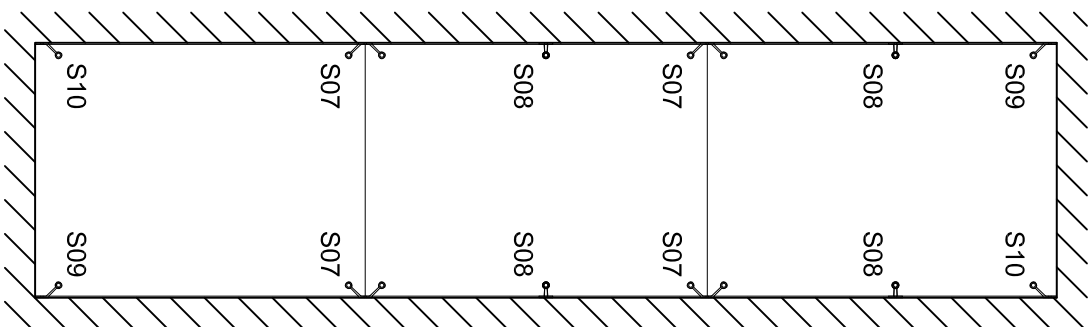

The Vision Group,
6 Barnes Close,
Brandon, Suffolk
IP27 0NY

TEL: +44 (0)1842 816086
FAX: +44 (0)1842 815515
WEB: www.spiralhardware.co.uk
E-MAIL: info@spiralhardware.co.uk

Copyright (c) - April 2008. All Rights Reserved

NOTES/SPECIFICATION:

EXAMPLE DETAILS

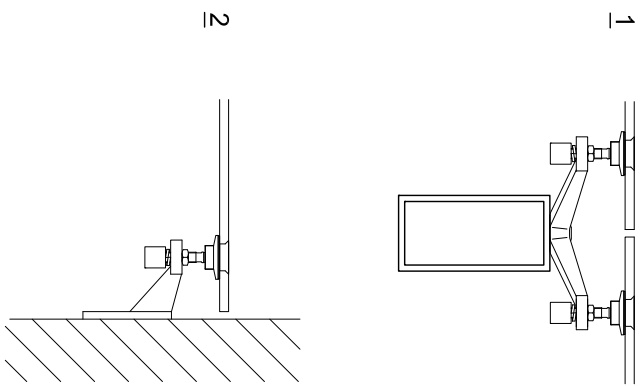

PRODUCT REF: SH/ATS/

DESCRIPTION:

ELEVATIONS SHOWING
FITTINGS TYPES LOCATIONS
*

DRAWING REF: SH/ATS/AE/001