

**REAR VIEW  
ON HINGE**  
(SCALE 1:2 (A4))

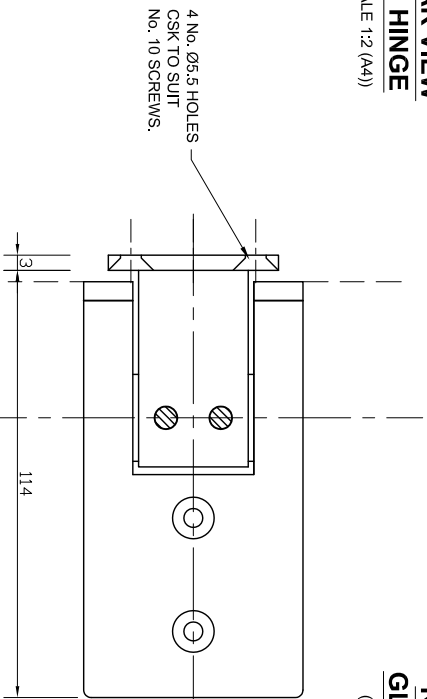

**REQUIRED  
GLASS PREP**  
(SCALE 1:2 (A4))

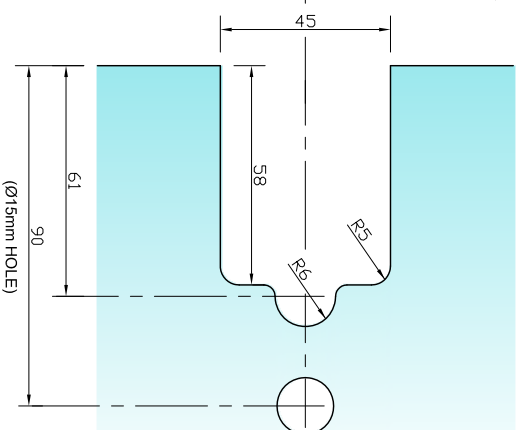

**PLAN VIEW  
ON HINGE**  
(SCALE 1:2 (A4))

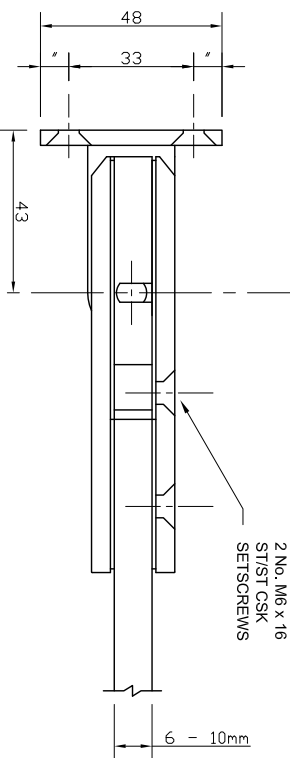

**FRONT VIEW  
ON HINGE**  
(SCALE 1:2 (A4))

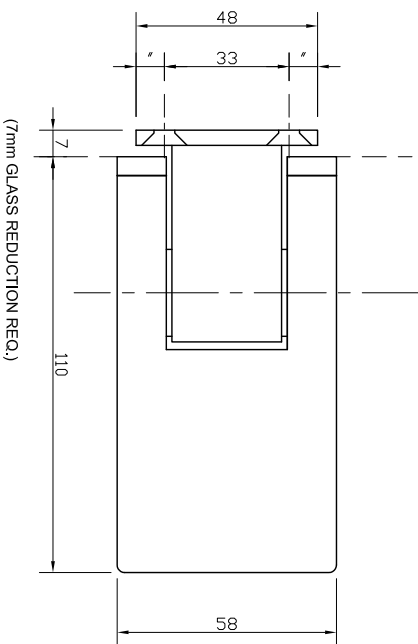

The Vision Group,  
6 Barnes Close,  
Brandon, Suffolk  
IP27 0NY

TEL: +44 (0)1842 816086  
FAX: +44 (0)1842 815515  
WEB: www.spiralhardware.co.uk  
E-MAIL: info@spiralhardware.co.uk

Copyright (c) - April 2008. All Rights Reserved

**NOTES/SPECIFICATION:**

ALL HINGE COMPONENTS IN SATIN STAINLESS STEEL.

PRODUCT SUITABLE FOR 6 TO 10mm TOUGHENED GLASS PANES.

HINGE SUPPLIED COMPLETE WITH:-

- 1) 2 No. x 1.7mm TRANSLUCENT RUBBER GLAZING WASHERS.
- 2) 2 No. x 1.1mm TRANSLUCENT RUBBER GLAZING WASHERS
- 3) 2 No. M6 x 16mm ST/ST HEX SOCKET HEAD CSK SETSCREWS
- 4) 1 No. HEX SOCKET ALLEN KEY TO SUIT
- 5) 4 No. 10 x 40mm POSI DRIVE SCREWS AND PLASTIC PLUGS

(NOTE CUSTOMER TO PROVIDE ALTERNATIVE FIXINGS WHERE REQUIRED)

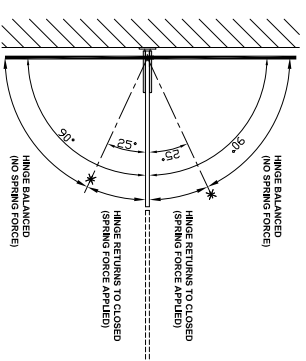

**PRODUCT REF: SH/PAS/H08**

DESCRIPTION: DIMENSIONED ELEVATIONS AND REQUIRED GLASS PREP DETAIL

DRAWING REF: SH/PAS/H08 - 001