

**REAR VIEW  
ON FITTING**

(SCALE 1:2 (A4))

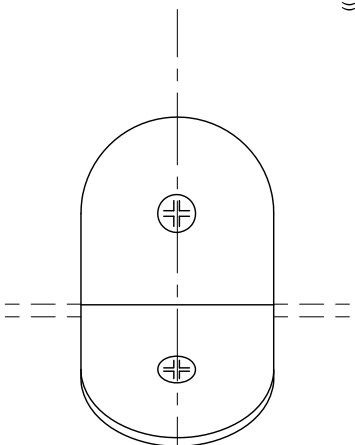

**REQUIRED  
GLASS PREP**  
TO BOTH  
GLASS PANES  
(SCALE 1:2 (A4))

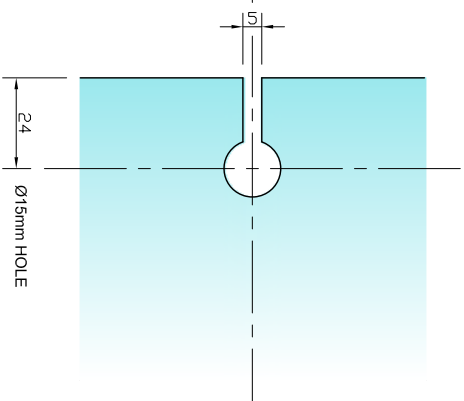

**PLAN VIEW  
ON FITTING**

(SCALE 1:2 (A4))

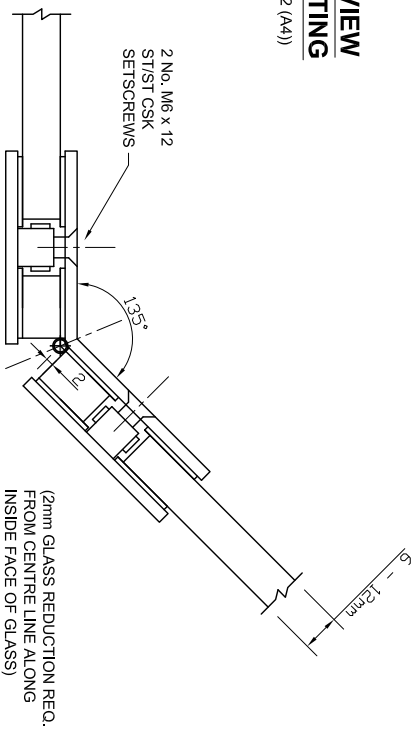

**FRONT VIEW  
ON FITTING**

(SCALE 1:2 (A4))

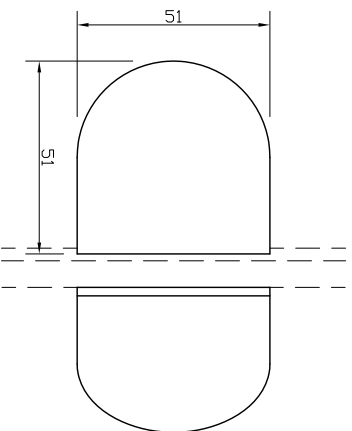

The Vision Group,  
6 Barnes Close,  
Brandon, Suffolk  
IP27 0NY

TEL: +44 (0)1842 816086  
FAX: +44 (0)1842 815515  
WEB: [www.spiralhardware.co.uk](http://www.spiralhardware.co.uk)  
E-MAIL: [info@spiralhardware.co.uk](mailto:info@spiralhardware.co.uk)

Copyright (c) - April 2008. All Rights Reserved

**NOTES/SPECIFICATION:**

ALL FITTING COMPONENTS IN SATIN STAINLESS STEEL.

PRODUCT SUITABLE FOR 6 TO 12mm TOUGHENED GLASS PANES.

FITTING SUPPLIED COMPLETE WITH:-

- 1) 4 No. x 1.25mm TRANSLUCENT RUBBER GLAZING WASHERS,
- 2) 2 No. M6 x 12mm ST/ST POSI DRIVE HEAD CSK SETSCREWS

(NOTE CUSTOMER TO PROVIDE ALTERNATIVE FIXINGS WHERE REQUIRED)

**PRODUCT REF:** SH/ART/B04

**DESCRIPTION:** DIMENSIONED ELEVATIONS AND  
REQUIRED GLASS PREP DETAIL

**DRAWING REF:** SH/ART/B04 - 001